

PACKAGE DIMENSIONS

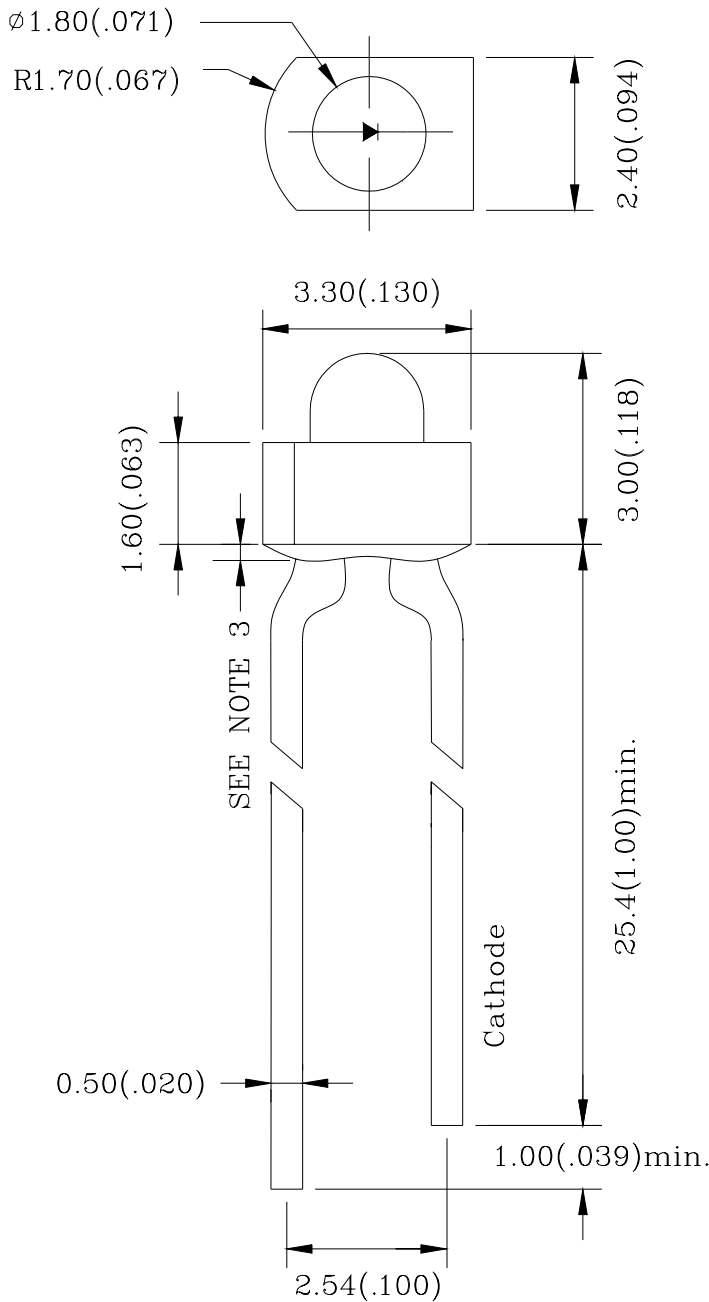

Note:

- 1.All Dimensions are in millimeters.
- 2.Tolerance is $\pm 0.25\text{mm} (0.010 \text{ "})$
Unless otherwise specified.
- 3.Protruded resin under flange is $1.5\text{mm} (0.059 \text{ "})$ max.
- 4.Lead spacing is measured where the leads emerge from the package.
- 5.Specification are subject to change without notice.
- 6.highlight $< -500\text{V}$ the led can withstand the max static level when assembling or operation.

1.8 mm DIA LED LAMP

HH-1.8WD-50

REV:A / 1

FEATURES

- * SUITABLE HIGH PULSE CURRENT OPERATION
- * EXTRA HIGH RADIANT POWER AND RADIANT INTENSITY
- * HIGH RELIABILITY
- * LOW FORWARD VOLTAGE

CHIP MATERIALS

- * Dice Material : GaInN/GaN
- * Light Color : ULTRA WHITE
- * Lens Color : WATER DIFFUSED

ABSOLUTE MAXIMUM RATING:(Ta=25°C)

SYMBOL	DESCRIPTION	ULTRA WHITE	UNIT
PAD	Power Dissipation Per Chip	80	mW
VR	Reverse Voltage Per Chip	5	V
IF	Average Forward Current Per Chip	20	mA
-	Derating Linear From 25°C Per Chip	0.4	mA/°C
Topr	Operating Temperature Range	-25°C to 85°C	
Tstg	Storage Temperature Range	-40°C to 85°C	
Lead Soldering Temperature { 1.6mm(0.063 inch) From Body } 260°C±5°C For 5 Seconds			

ELECTRO-OPTICAL CHARACTERISTICS:(Ta=25°C)

SYMBOL	DESCRIPTION	TEST CONDITION	MIN.	TYP.	MAX.	UNIT
VF	Forward Voltage	IF = 20mA		3.2		V
IR	Reverse Current	VR = 5V			100	µA
2θ1/2	Half Intensity Angle	IF = 20mA		50		deg
IV	Luminous Intensity	IF = 20mA		1900		mcd
X	Chromaticity Coordinates	IF = 20mA		0.29		
Y		IF = 20mA		0.30		

1.8 mm DIA LED LAMP

HH-1.8WD-50

REV:A/1

